

## TELESCOPIC JOINT

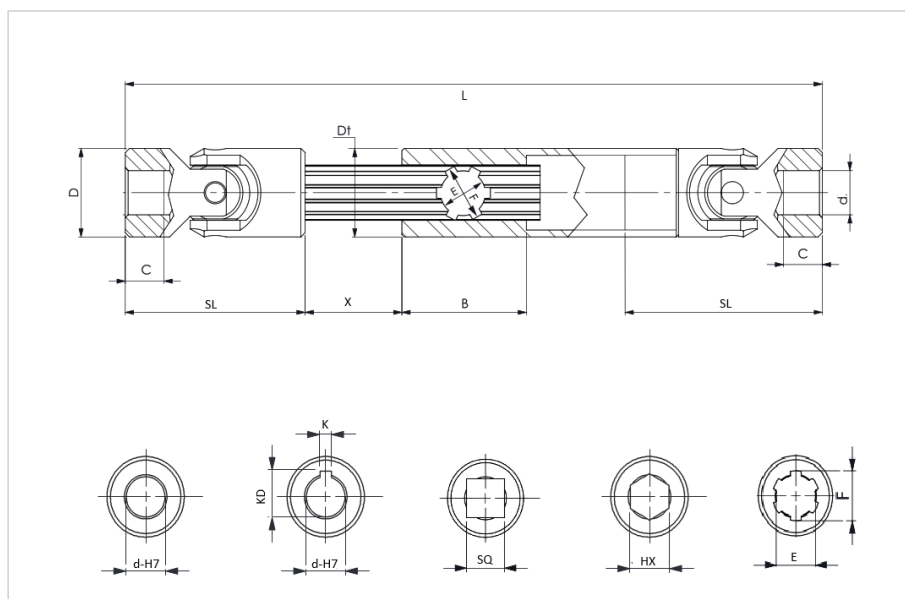

Preferred Lengths (L)										
Size	Length	Dimensions [mm] (L-min. / L-max.)								
T-22	min	140	160	180	230					
	max	170	200	240	330					
T-25	min	160	180	200	220	250	280	300		
	max	190	225	270	300	355	420	450		
T-28	min	170	180	200	220	250	280	300	350	400
	max	200	220	260	300	350	420	450	550	650
T-32	min	190	210	240	250	275	300	380	400	
	max	220	250	320	350	390	430	590	630	
T-36	min	230	250	270	290	300	400	500		
	max	280	320	370	400	415	620	820		
T-42	min	250	270	290	320	380	420	500		
	max	300	340	380	440	560	640	800		
T-45	min	250	270	290	330	350	470			
	max	280	320	350	430	470	710			
T-50	min	295	310	350	380	420	460	500		
	max	345	375	450	500	590	660	745		
T-58	min	330	350	370	400	450	500	540		
	max	380	420	455	510	620	720	795		

### Example:

Type	Dia	Bore	Length (min/max)	Profile
T	32	16	190/220	K